

TKD DN 15÷50



DUAL BLOCK® 3-way ball valve



TKD DN 15÷50

FIP has developed a TKD DUAL BLOCK® ball valve to introduce a high reference standard in thermoplastic valve design. TKD is a True Union diverting and mixing ball valve that meets the most stringent needs required in industrial applications.



DUAL BLOCK® 3-WAY BALL VALVE

- Connection system for weld and threaded joints
- Patented **SEAT STOP®** ball seat carrier system that lets you micro-adjust ball seats and minimise axial force effects
- Easy radial disassembly allowing quick replacement of O-rings and ball seats without any need for tools
- PN10 **True Union valve body** made for PP-H injection moulding equipped with built-in bores for actuation. ISO 9393 compliant test requisites
- Option of disassembling downstream pipes with the valve in the closed position
- High surface finish stem with double O-Ring and double groove ball connection, equipped with **optical position indicator** for correct handle installation
- **Integrated bracket** for valve anchoring
- Possibility of installing pneumatic and/or electric actuators thanks to the robust integrated bracket for valve anchoring for easy and quick automation using the Power Quick module (optional)
- Possibility to have handle with integrated LSQT limit micro switch, even as a retrofit in existing installations

Technical specifications	
Construction	3-way True Union ball valve with locked carrier and lockable union nuts
Size range	DN 15 ÷ 50
Nominal pressure	PN 10 with water at 20° C
Temperature range	0 °C ÷ 100 °C
Coupling standards	Welding: EN ISO 15494 Can be coupled to pipes according to EN ISO 15494 Thread: ISO 228-1, EN 10226-1/2
Reference standards	Construction criteria: EN ISO 16135, EN ISO 15494 Test methods and requirements: ISO 9393 Installation criteria: EN 14728, DVS 2207-11, DVS 2208-1, UNI 11318 Actuator couplings: ISO 5211
Valve material	PP-H
Seal material	EPDM, FKM (standard size O-Rings); PTFE (ball seats)
Control options	Manual control; electric actuator; pneumatic actuator

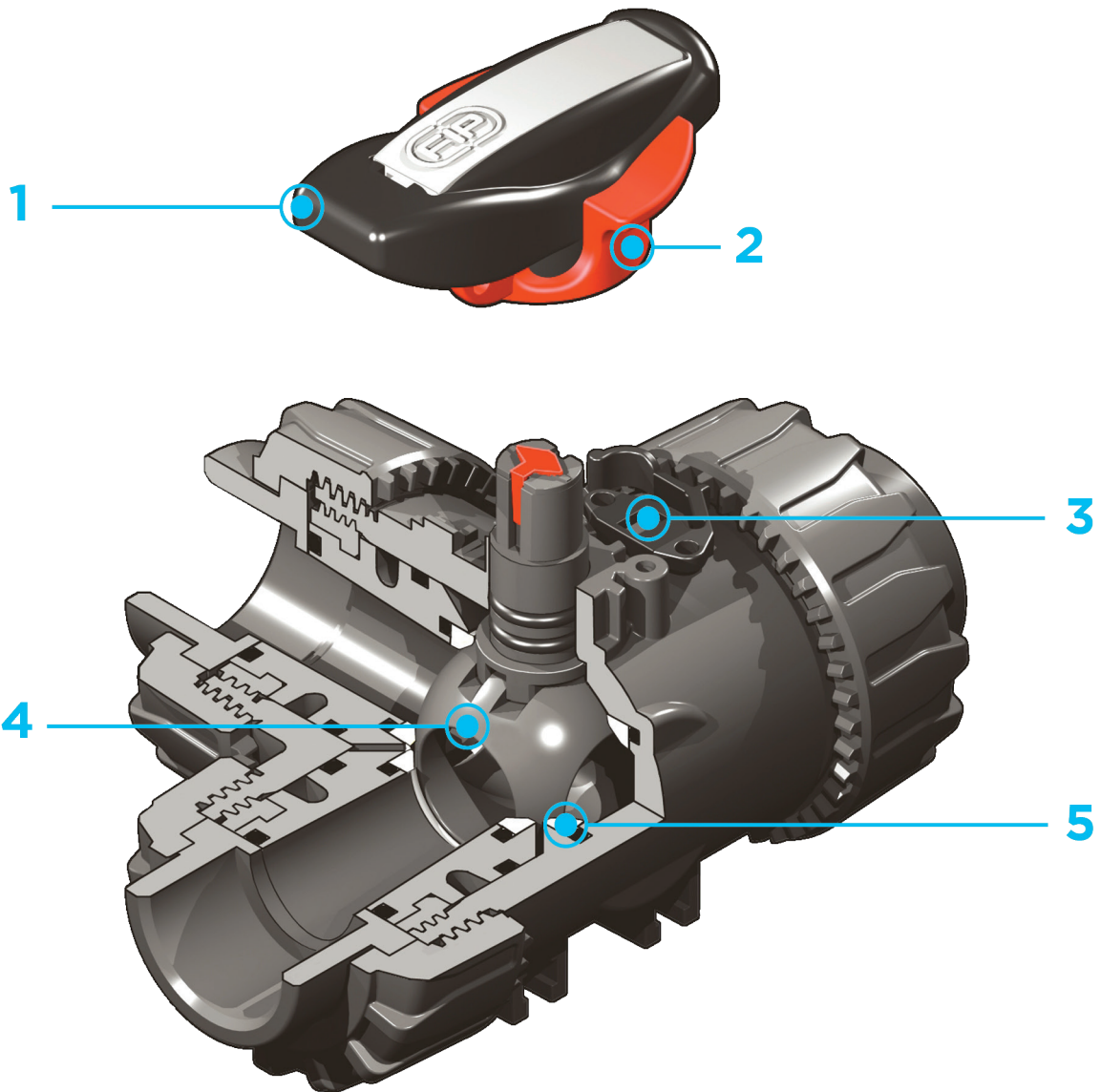

1 Ergonomic HIPVC handle equipped with removable tool to adjust the ball seat carrier. Possibility of installing the **LTKD stroke limiter** (available as an accessory) that permits ball and handle rotation only for set opening and closing angles at 90° or 180°

2 Handle lock 0°- 90° SHKD

(available as an accessory) ergonomically operable during service and padlockable

3 **DUAL BLOCK®** patented lock system that ensures union nut tightening hold even in severe conditions such as vibrations or heat dilation

4 **Ball shutter** high surface finish with floating type full passage with **T or L port**

5 **4 PTFE ball seat system** that compensates axial force guaranteeing optimal manageability and long working life

DIMENSIONS

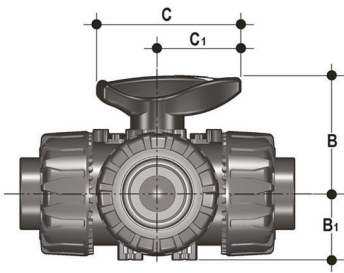

Dimensions shared by all versions

d	DN	B	B ₁	C	C ₁
20	15	54	29	67	40
25	20	65	35	85	49
32	25	70	39	85	49
40	32	83	46	108	64
50	40	89	52	108	64
63	50	108	62	134	76

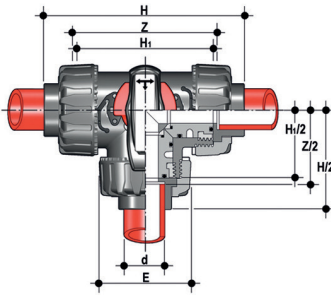

TKDIM

DUAL BLOCK® 3-way ball valve with metric plain socket ends for socket welding, - T bore.

d	DN	PN	E	H	H ₁	Z	g	EPDM code	FKM code
20	15	10	54	117	80	88	195	TKDIM020E	TKDIM020F
25	20	10	65	144	100	112	350	TKDIM025E	TKDIM025F
32	25	10	73	158	110	122	505	TKDIM032E	TKDIM032F
40	32	10	86	184	131	143	820	TKDIM040E	TKDIM040F
50	40	10	98	219	148	172	1070	TKDIM050E	TKDIM050F
63	50	10	122	267	179	212	1795	TKDIM063E	TKDIM063F

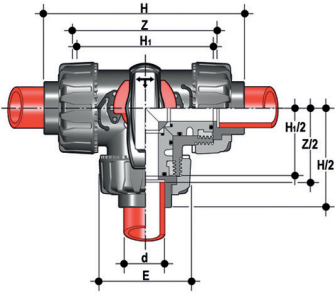

LKDIM

DUAL BLOCK® 3-way ball valve with metric plain socket ends for socket welding, - L bore.

d	DN	PN	E	H	H ₁	Z	g	EPDM code	FKM code
20	15	10	54	117	80	88	195	LKDIM020E	LKDIM020F
25	20	10	65	144	100	112	350	LKDIM025E	LKDIM025F
32	25	10	73	158	110	122	505	LKDIM032E	LKDIM032F
40	32	10	86	184	131	143	820	LKDIM040E	LKDIM040F
50	40	10	98	219	148	172	1070	LKDIM050E	LKDIM050F
63	50	10	122	267	179	212	1795	LKDIM063E	LKDIM063F

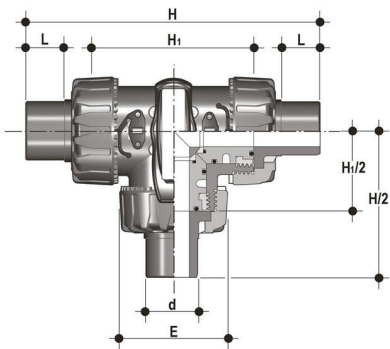

TKDDM

DUAL BLOCK® 3-way ball valve with male ends for socket welding, metric series, T-port ball.

d	DN	PN	E	H	H ₁	L	g	EPDM code	FKM code
20	15	10	54	140	80	16	205	TKDDM020E	TKDDM020F
25	20	10	65	175	100	18	360	TKDDM025E	TKDDM025F
32	25	10	73	188	110	20	515	TKDDM032E	TKDDM032F
40	32	10	86	220	131	22	835	TKDDM040E	TKDDM040F
50	40	10	98	251	148	23	1100	TKDDM050E	TKDDM050F
63	50	10	122	294	179	29	1830	TKDDM063E	TKDDM063F

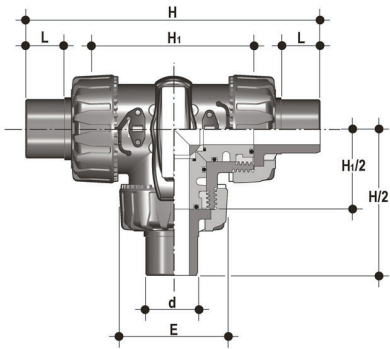

LKDDM

DUAL BLOCK® 3-way ball valve with male ends for socket welding, metric series, L-port ball.

d	DN	PN	E	H	H ₁	L	g	EPDM code	FKM code
20	15	10	54	140	80	16	205	LKDDM020E	LKDDM020F
25	20	10	65	175	100	18	360	LKDDM025E	LKDDM025F
32	25	10	73	188	110	20	515	LKDDM032E	LKDDM032F
40	32	10	86	220	131	22	835	LKDDM040E	LKDDM040F
50	40	10	98	251	148	23	1100	LKDDM050E	LKDDM050F
63	50	10	122	294	179	29	1830	LKDDM063E	LKDDM063F

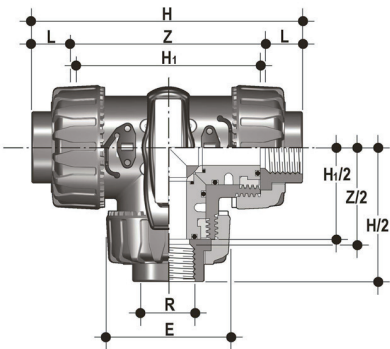

TKDFM

DUAL BLOCK® 3-way ball valve with BS parallel socket threaded ends, T bore.

R	DN	PN	E	H	H ₁	L	Z	g	EPDM code	FKM code
1/2"	15	10	54	117	80	15	87	195	TKDFM012E	TKDFM012F
3/4"	20	10	65	143	100	16	114	350	TKDFM034E	TKDFM034F
1"	25	10	73	157	110	19	120	505	TKDFM100E	TKDFM100F
1" 1/4	32	10	86	185	131	21	140	820	TKDFM114E	TKDFM114F
1" 1/2	40	10	98	217	148	21	172	1070	TKDFM112E	TKDFM112F
2"	50	10	122	266	179	26	211	1795	TKDFM200E	TKDFM200F

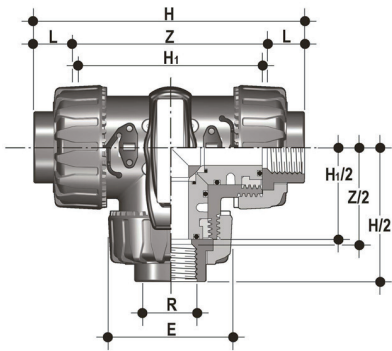

LKDFM

DUAL BLOCK® 3-way ball valve with BS parallel socket threaded ends, L bore.

R	DN	PN	E	H	H ₁	L	Z	g	EPDM code	FKM code
1/2"	15	10	54	117	80	15	87	195	LKDFM012E	LKDFM012F
3/4"	20	10	65	143	100	16	114	350	LKDFM034E	LKDFM034F
1"	25	10	73	157	110	19	120	505	LKDFM100E	LKDFM100F
1" 1/4	32	10	86	185	131	21	140	820	LKDFM114E	LKDFM114F
1" 1/2	40	10	98	217	148	21	172	1070	LKDFM112E	LKDFM112F
2"	50	10	122	266	179	26	211	1795	LKDFM200E	LKDFM200F

ACCESSORI

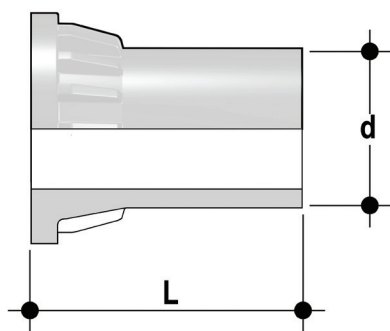

CVDM

End connectors in PP-H SDR 11 PN 10, long spigot, for butt welding

d	DN	PN	L	SDR	Code
20	15	10	55	11	CVDM11020
25	20	10	70	11	CVDM11025
32	25	10	74	11	CVDM11032
40	32	10	78	11	CVDM11040
50	40	10	84	11	CVDM11050
63	50	10	91	11	CVDM11063

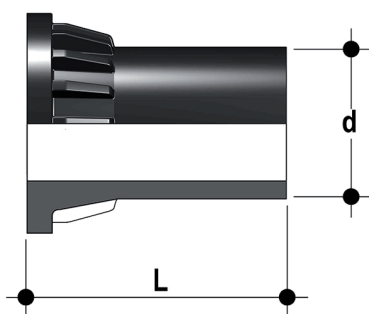

CVDE

Long spigot PE100 end connectors for joints with electrofusion fittings or for butt welding

d	DN	PN	L	SDR	Code
20	15	16	55	11	CVDE11020
25	20	16	70	11	CVDE11025
32	25	16	74	11	CVDE11032
40	32	16	78	11	CVDE11040
50	40	16	84	11	CVDE11050
63	50	16	91	11	CVDE11063



SHKD

Handle block kit 0° - 90° lockable

d	DN	Code
16 - 20	10 - 15	SHKD020
25 - 32	20 - 25	SHKD032
40 - 50	32 - 40	SHKD050
63	50	SHKD063

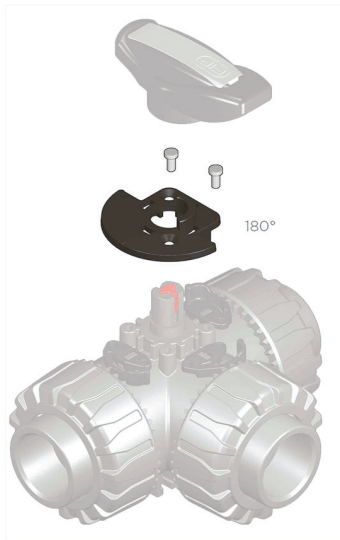
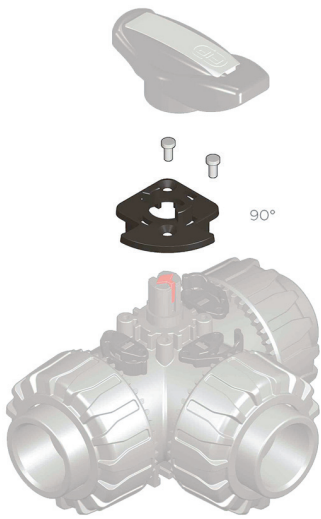

LTKD

The LTKD stroke limiter specifically permits handle and ball rotation only at set opening and closing angles. The LTKD090 version permits operations for 90° angles while the LTKD180 version for 180° angles. The LTKD stroke limiter is made up of a single removable plate made of technopolymer. Designed for ISO 5211 bore and specifically designed to be directly housed on the valve body mounting flange. It is secured to the valve body by self-tapping screws or plastic rivets.

d	DN	90° code	180° code
16 - 20	10 - 15	LTKD090020	LTKD180020
25 - 32	20 - 25	LTKD090032	LTKD180032
40 - 50	32 - 40	LTKD090050	LTKD180050
63	50	LTKD090063	LTKD180063

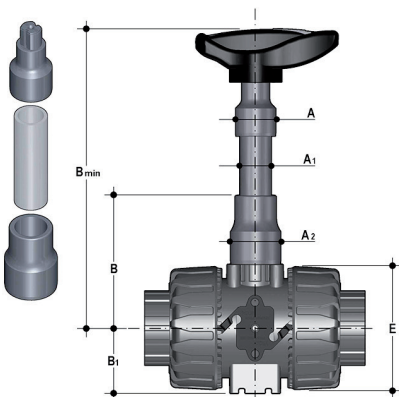

PSKD

Stem extension

d	DN	A	A ₁	A ₂	E	B	B ₁	B _{min}	Code
20	15	32	25	32	54	70	29	139,5	PSKD020
25	20	32	25	40	65	89	34,5	164,5	PSKD025
32	25	32	25	40	73	93,5	39	169	PSKD032
40	32	40	32	50	86	110	46	200	PSKD040
50	40	40	32	50	98	116	52	206	PSKD050
63	50	40	32	59	122	122	62	225	PSKD063

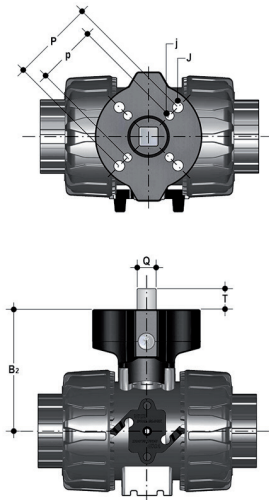

Power Quick/CP

The valve can be equipped with pneumatic actuators, using the PP-GR module reproducing the drilling pattern foreseen by ISO 5211

d	DN	B ₂	Q	T	p x j	P x J	Code
16	10	58	11	12	F03 x 5,5	F04 x 5,5	PQCP020
20	15	58	11	12	F03 x 5,5	F04 x 5,5	PQCP020
25	20	69	11	12	*F03 x 5,5	F05 x 6,5	PQCP025
32	25	74	11	12	*F03 x 5,5	F05 x 6,5	PQCP032
40	32	91	14	16	F05-07*	F07 x 8,5	PQCP040
50	40	97	14	16	F05-07*	F07 x 8,5	PQCP050
63	50	114	14	16	F05-07*	F07 x 8,5	PQCP063

*F04 x 5.5 on request

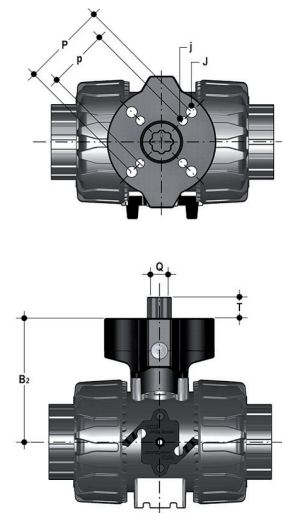

Power Quick/CE

The valve can be equipped with electric actuators, using the PP-GR module reproducing the drilling pattern foreseen by ISO 5211

d	DN	B ₂	Q	T	p x j	P x J	Code
16	10	58	14	16	F03 x 5,5	F04 x 5,5	PQCE020
20	15	58	14	16	F03 x 5,5	F04 x 5,5	PQCE020
25	20	69	14	16	*F03 x 5,5	F05 x 6,5	PQCE025
32	25	74	14	16	*F03 x 5,5	F05 x 6,5	PQCE032
40	32	91	14	16	F05 x 6,5	F07 x 8,5	PQCE040
50	40	97	14	16	F05 x 6,5	F07 x 8,5	PQCE050
63	50	114	14	16	F05 x 6,5	F07 x 8,5	PQCE063

*F04 x 5.5 on request

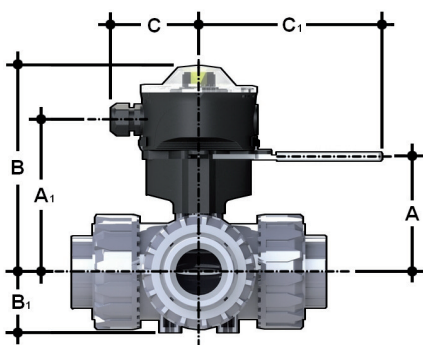

LS Quick Kit

The Limit Switch Quick Kit allows the fast and secure installation of the FIP LSQT to the VKD valves. The body is in PP-GR and the handle is in stainless steel AISI 316. The handle block at 0° and 90° is also available by default (hole diameter 6.5 mm). The kit can be assembled on the valve even if already installed on the system. For technical data of the LSQT box see FIP actuated valves catalogue.

d	DN	A	A ₁	B	B ₁	C	C ₁	Code
16	10	60	91,5	137	29	76,5	157,5	LSQKIT20
20	15	60	91,5	137	29	76,5	157,5	LSQKIT20
25	20	71	102,5	148	34,5	76,5	157,5	LSQKIT25
32	25	76	107,5	153	39	76,5	157,5	LSQKIT32
40	32	93	124,5	170	46	76,5	157,5	LSQKIT40
50	40	99	130,5	176	52	76,5	157,5	LSQKIT50
63	50	116	147,5	193	62	76,5	157,5	LSQKIT63

FASTENING AND SUPPORTING



All valves, whether manual or actuated, must be adequately supported in many applications.

The TKD valve series is therefore ready to be equipped with threaded supporting brackets (optional) that permits direct anchoring of the valve body without the need of other components.

Using standard threaded nuts (not included) made of STAINLESS steel, you can anchor the valve on 4 fastening points.

d	DN	A	a	J
16	10	31	20	M5 x 8
20	15	31	20	M5 x 8
25	20	31	20	M5 x 8
32	25	31	20	M5 x 8
40	32	50	30	M6 x 10
50	40	50	30	M6 x 10

* With threaded inserts

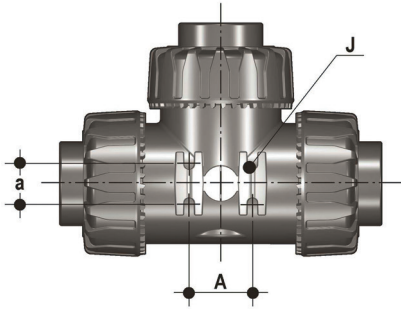

COMPONENTS

EXPLODED VIEW

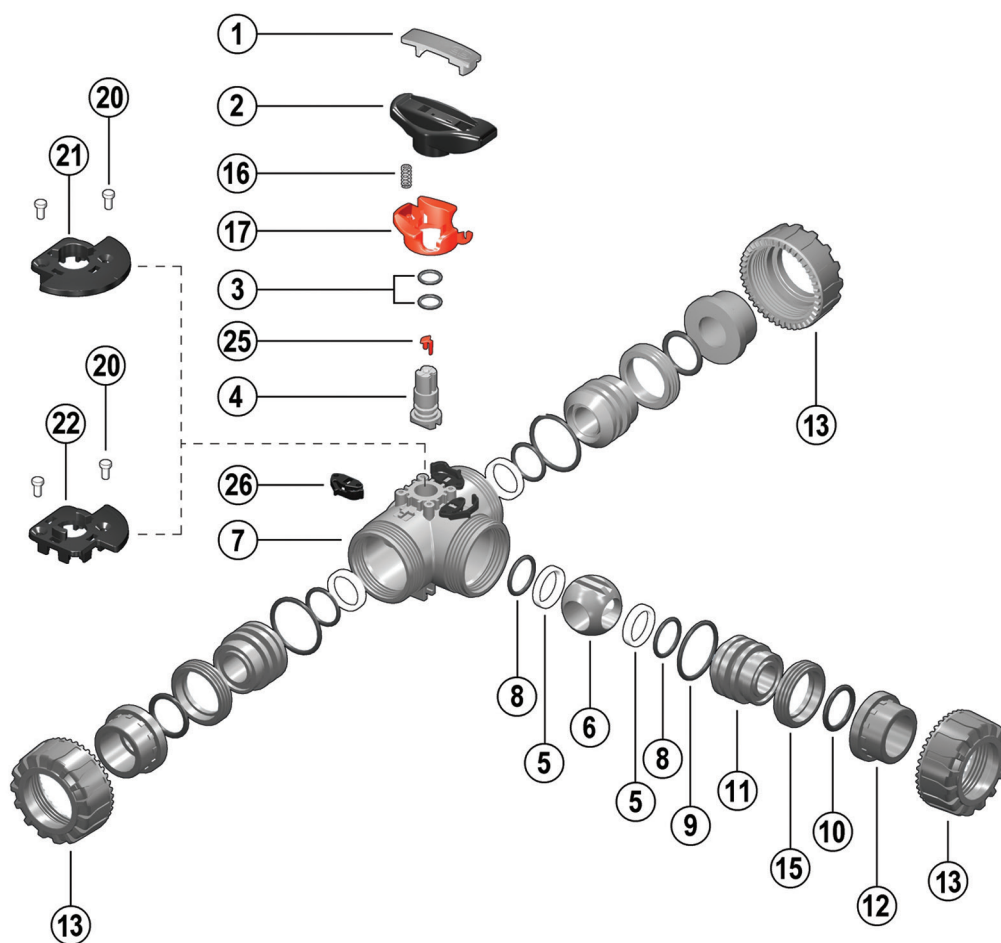

- | | | | | | |
|----------|--------------------------------------|-----------|---------------------------------------|-----------|--|
| 1 | Handle insert (PVC-U - 1) | 9 | Radial seal O-Ring (EPDM or FKM - 3) | 16 | Spring - SHKD accessory (STAINLESS steel - 1)** |
| 2 | Handle (HIPVC - 1) | 10 | Socket seal O-Ring (EPDM or FKM - 3)* | 17 | Safety handle block - SHKD accessory (PP-GR - 1)** |
| 3 | Stem O-ring (EPDM or FKM - 2)* | 11 | Ball seat carrier (PP-H - 3) | 20 | Rivet for LTKD (POM - 2)** |
| 4 | Stem (PP-H - 1) | 12 | End connector (PP-H - 3)* | 21 | LTKD 180° (POM - 1)** |
| 5 | Ball seat (PTFE - 4)* | 13 | Union nut (PP-H - 3) | 22 | LTKD 90° (POM - 1)** |
| 6 | Ball (PP-H - 1) | 15 | Threaded ring (PP-H - 3) | 25 | Position indicator (POM - 1) |
| 7 | Body (PP-H - 1) | | | 26 | DUAL BLOCK® (POM - 3) |
| 8 | Ball seat O-Rings (EPDM or FKM - 4)* | | | | |

* Spare parts

** Accessories

The component material and quantity supplied are indicated in the parentheses.

DISASSEMBLY

- 1) Isolate the valve from the line (release the pressure and empty the pipeline).
- 2) Unlock the union nuts by pressing the lever on the DUAL BLOCK® (26) along the axis and separate it from the union nut (fig. 1). It is also possible to completely remove the block device from the body of the valve.
- 3) Unscrew the union nuts (13) and extract the body (7).
- 4) After turning the handle (2) to the position with the three arrows pointing at the three ports (for L-port ball with two arrows facing the ports a and b), extract the insert (1) from the handle (2) and insert the two protrusions in the corresponding apertures in the threaded rings (15), extracting the carriers (11) by turning counterclockwise.
- 5) Extract the ball (6) from the central port being careful not to damage the seat surface.
- 6) Remove the PTFE ball seats (5) and O-Rings (8, 9, 10) from the carriers (11).
- 7) Pull the handle (2) upwards to remove it from the stem (4).
- 8) Press the stem (4) into the body and extract it.
- 9) Remove the PTFE ball seat (5) with relevant O-ring (8) from inside the valve body.
- 10) Remove the stem (4) O-rings (3) from their seats.

ASSEMBLY

- 1) Insert the O-rings (3) on the stem (4).
- 2) Insert the O-ring (8) in the seat in the valve body and, next, the PTFE ball seat (5).
- 3) Insert the stem (4), from the interior, in the body, being sure the three marks on the socket correspond to the three outlets.
- 4) Insert the ball (6) from the central port b, being careful that the three bores match the three outlets (for L-port ball, the two bores must match the a and b outlets).
- 5) Insert the O-rings (8), PTFE ball seats (5), socket seal O-rings (10) and radial seal O-rings (9) in their seats on the carriers (11).
- 6) Insert the three carriers (11) with the relevant threaded rings (15), screwing in clockwise with the handle insert (1) and starting from the one on the central outlet b.
- 7) Press the handle (2) on the stem (4), being careful to match the printed arrows with the lines on the stem (fig. 2-3).
- 8) Return the insert (1) in the handle (2)
- 9) Insert the valve between the end connectors (12) and tighten the union nuts (13), making sure that the socket seal O-rings (10) do not exit their seats.



Note: during assembly operations, it is advisable to lubricate the rubber seals. Mineral oils are not recommended for this task as they react aggressively with EPDM rubber.

Fig. 1



Fig. 2

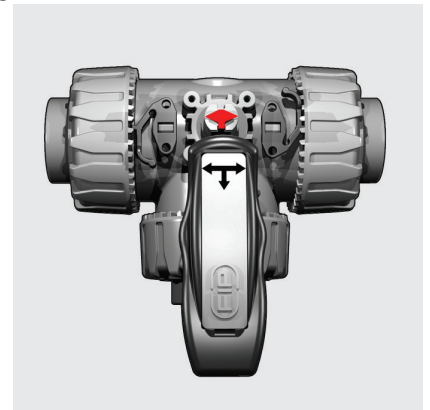

Fig. 3

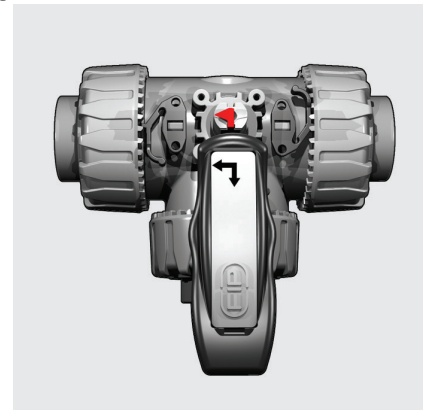

Fig. 4



INSTALLATION

Before proceeding with installation, please follow these instructions carefully:

- 1) Check that the pipes to be connected to the valve are aligned in order to avoid mechanical stress on the threaded joints.
- 2) Check that the DUAL BLOCK® union nut locking device (26) is fitted to the valve body.
- 3) To release the union nuts (13), axially press the release lever to separate the lock and then unscrew it in the counter-clockwise direction.
- 4) Unscrew the three union nuts (13) and insert them on the pipe segments.
- 5) Solvent weld or screw the end connectors (12) onto the pipe ends.
- 6) Position the valve body between the end connectors (12) and fully tighten the union nuts (13) manually by rotating clockwise, without using wrenches or other tools that could damage the union nut surface.
- 7) Lock the union nuts by returning the DUAL BLOCK® to its housing, pressing on it until the hinges lock on the union nuts.
- 8) If necessary, support the pipework with FIP pipe clips or by means of the carrier built-into the valve itself (see paragraph "fastening and supporting").

The TKD valve can be equipped with a handle lock to prevent ball rotation (available as an accessory). When the block (16, 17) is installed, lift the lever (17) and rotate the handle.

A padlock can also be installed on the handle to protect the system against tampering (fig. 4).

Seals can be adjusted using the extractable insert on the handle (fig. 5-6). After positioning the ball as in figure 7-8, using this insert as a tool you can adjust the seals by screwing in the carriers following the indicated sequence (fig. 7-8).

A further fine-tuning of the seals can be done with the valve installed on the pipe by simply tightening the union nuts.

This "micro adjustment", only possible with FIP valves thanks to the patented "Seat stop system", allows the seal to be recovered where PTFE ball seats are worn due to a high number of operations.

WARNINGS

Always avoid sudden closing manoeuvres and protect the valve from accidental operations.

Fig.5



Fig.6



Fig.7

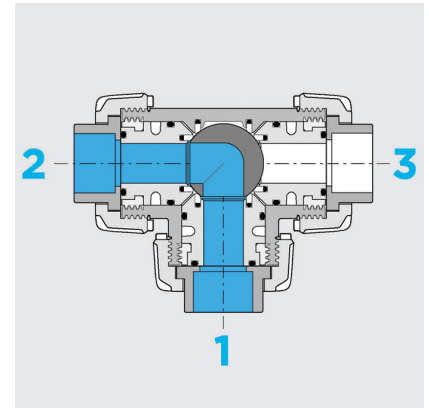

Fig.8

