

FLS pH/ORP 600

C-PVC body flat surface electrode



FLS PH/ORP 600

This line of FLS sensors constitutes the most robust model of traditional flat surface electrodes with a further enhanced self-cleaning effect. Installation and maintenance are easy thanks to the fast BNC connection. A double-junction reference with sealed gel has been integrated into the electrode body. This model enables an additional barrier against the contamination of the reference gel and allows the use of such electrodes in critical applications prolonging the duration of the working life. The pH glass is placed centrally in the flat surface and surrounded by a large porous plastic coupling that offers excellent contact between reference and liquid. Model with amplified signal is available for long-distance connection and metal foot in ground liquid. The availability of a wide range of accessories allows for in-line, flush-mounted or immersion installation.

C-PVC BODY FLAT SURFACE ELECTRODE

APPLICATIONS

- Water and wastewater treatment
- Prechlorination and dechlorination
- Neutralisation systems
- Water quality monitoring
- Ozone treatment
- Cooling towers
- Boilers
- Production of hypochlorite solutions
- Cellulose pulp bleaching
- Aquaculture
- Fruit and vegetable washing
- Drying of textile products

MAIN CHARACTERISTICS

- Availability of models for pH and ORP
- Electrodes with flat measuring surface
- Double coupling technology
- High reference gel volume
- High protection from process contamination
- Quick and easy installation system
- BNC connection
- In-line, flush-mounted or immersion installation
- Cost-effective adapters
- HF (pH) option for analysis on liquids containing hydrofluoric acid (max 2%)
- LC (pH) option on request for low conductivity water (<100 $\mu\text{S}/\text{cm}$)
- DA option for the presence of eddy currents or for long distances thanks to signal amplification

TECHNICAL DATA

General information	Operating range: <ul style="list-style-type: none">– Electrodes for pH: 0–14 pH (0–12.3 pH without Na+ error)– Electrodes for ORP: ±2000 mV
	Pipe size range: from DN15 to DN100 (da 0,5" a 4")
	Value at 0 mV of the new electrodes: 7,00 pH ±0,2 pH
	New electrode efficiency: > 97% at 25 °C (77 °F)
	Response time of new electrodes: <ul style="list-style-type: none">– pH: 6 s for 95% signal change– ORP: depends on the application
	Reference solution: <ul style="list-style-type: none">– Type: double sealed junction– Electrolyte: solidified gel 3.5 M KCl 0.1 M KCl for electrode model LC / solidified gel 3.5 M KCl– Secondary junction: nylon filament– Wiring: Ag/AgCl
	Connection to the process: <ul style="list-style-type: none">– In-line installation:– 1/2", 3/4" threaded nipple– FLS installation adapter– Submersible installation– Hot-tap installation
	Max operating pressure/temperature: <ul style="list-style-type: none">– 6.7 bar at 75°C (100 psi at 170°F)– 5.7 bar at 81°C (85 psi at 180°F)
	Materials in contact with liquids: <ul style="list-style-type: none">– Body: C-PVC (PVDF on request only)– Reference coupling: Porous HDPE– Detection surface: glass membrane (pH) or glass sealed platinum (ORP)
	O-ring: FKM (Viton)
Standards & Approvals	Manufactured under ISO 9001 Manufactured under ISO 14001 CE EAC

PRODUCT CODES

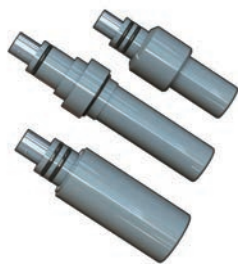

ORP6XX CD

C-PVC double junction Flat surface electrodes

Code	Characteristics	Applications/ Operative Range	Reference solution	Detection surface	Cable*	Connection	Installation	Weight (gr.)
ORP660CD	-	-	KCl 3.5 M	platinum	CN 653	Twist-lock (BNC)	EG66P MK660	100
ORP650CD	-	-	KCl 3.5 M	platinum	CN 653 CN653 TC1	Twist-lock (BNC)	MIFV20X05 MIMC20X05	100
ORP655CD	With pressurized filling gel	-	KCl 3.5 M	platinum	CN 653	Twist-lock (BNC)	WT675 WT675 TC1	100
ORP660CDDA	Signal amplified	Presence of stray currents	KCl 3.5 M	platinum	CN 653	Twist-lock (BNC)	EG66P MK660	200
ORP650CDDA	Signal amplified	Presence of stray currents	KCl 3.5 M	platinum	CN 653 CN653 TC1	Twist-lock (BNC)	MIFV20X05 MIMC20X05	200

* (Sold separately)

PH6XX CD

C-PVC double junction Flat surface electrodes

Code	Characteristics	Applications/ Operative Range	Reference solution	Detection surface	Cable*	Connection	Installation	Weight (gr.)
PH660CD	-	-	KCl 3.5 M	flat pH glass membrane	CN 653	Twist-lock (BNC)	EG66P MK660	100
PH650CD	-	-	KCl 3.5 M	flat pH glass membrane	CN 653 CN 653 TC1	Twist-lock (BNC)	MIFV20X05 MIMC20X05	100
PH655CD	With pressurized filling gel	-	KCl 3.5 M	flat pH glass membrane	CN 653	Twist-lock (BNC)	WTF675 WTF675 TC1	100
PH660CDHF	-	Liquids with Hydrofluoric acid (max 2%)	KCl 3.5 M	flat pH glass membrane	CN 653	Twist-lock (BNC)	EG66P MK660	100
PH650CDHF	-	Liquids with Hydrofluoric acid (max 2%)	KCl 3.5 M	flat pH glass membrane	CN 653 CN 653 TC1	Twist-lock (BNC)	MIFV20X05 MIMC20X05	100
PH655CDHF	With pressurized filling gel	Liquids with Hydrofluoric acid (max 2%)	KCl 3.5 M	flat pH glass membrane	CN 653	Twist-lock (BNC)	WTF675 WTF675 TC1	100
PH660CDDA	Signal amplified	Presence of stray currents	KCl 3.5 M	flat pH glass membrane	CN 653	Twist-lock (BNC)	EG66P MK660	200
PH650CDDA	Signal amplified	Presence of stray currents	KCl 3.5 M	flat pH glass membrane	CN 653 CN 653 TC1	Twist-lock (BNC)	MIFV20X05 MIMC20X05	200
PH660CDLC	-	Liquids with low conductivity (10 µS/cm <conductivity<100µS/ cm)	KCl 0.1 M	flat pH glass membrane	CN 653	Twist-lock (BNC)	EG66P MK660	100
PH650CDLC	-	Liquids with low conductivity (10 µS/cm <conductivity<100µS/ cm)	KCl 0.1 M	flat pH glass membrane	CN 653 CN653 TC1	Twist-lock (BNC)	MIFV20X05 MIMC20X05	100
PH655CDLC	With pressurized filling gel	Liquids with low conductivity (10 µS/cm <conductivity<100µS/ cm)	KCl 0.1 M	flat pH glass membrane	CN 653	Twist-lock (BNC)	WTF675 WTF675 TC1	100

* (Sold separately)

TECHNICAL DRAWINGS

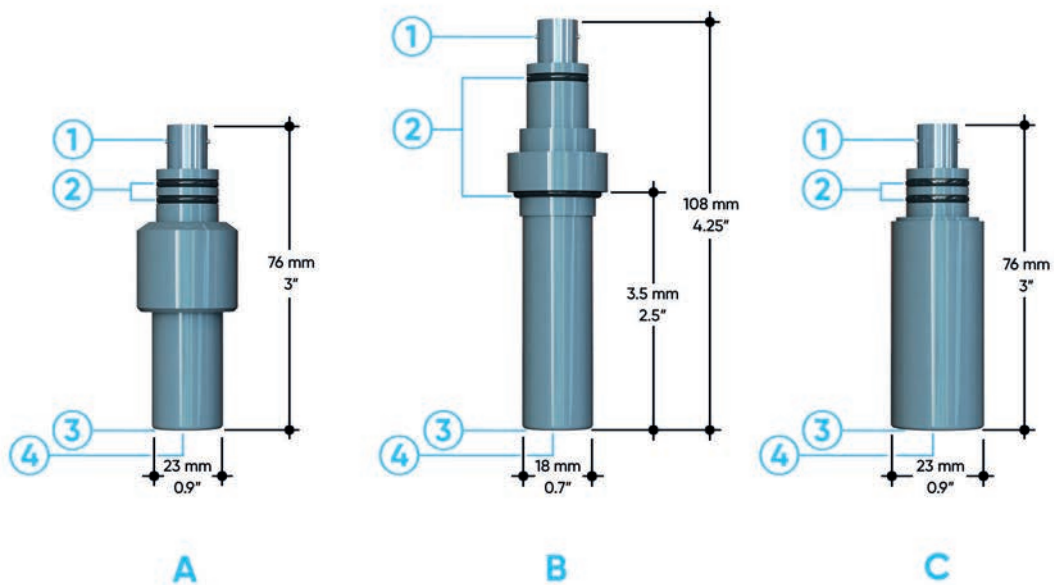

- A** Submersible PH650, ORP650
- B** In-line PH660, ORP660
- C** Insertion/Hot-tap PH655, ORP655

- 1** BNC coupling
- 2** Viton O-ring
- 3** Porous HDPE coupling

- 4** Platinum or pH glass