

FLS M9.07



Dual parameter conductivity and flow monitor and transmitter



FLS M9.07

The FLS M9.07 dual-parameter monitor and transmitter is a device that combines conductivity and flow measurements. A 4" wide full graphic display shows measured values clearly together with a lot of other useful information. Moreover, due to a multicolour display plus a powerful backlight, measurement status can be determined easily from afar too. A tutorial software guarantees a mistake-proof and fast set up of every parameter. Various types of calibration can be performed as needed for both measurements. The 4-20 mA output dedicated to each measurement allows you to send the values to a remote external device. Appropriate combination of digital outputs allows customised setups for any process to be controlled. The USB port on the back allows you to update the software with a wide range of customisation services as standard and on-demand.

DUAL PARAMETER CONDUCTIVITY AND FLOW MONITOR AND TRANSMITTER

APPLICATIONS

- Water treatment and regeneration
- Industrial wastewater treatment and recovery
- Softening
- Filtration systems
- Desalination
- Production of demineralised water
- Reverse osmosis
- cooling monitoring
- Processing and manufacturing industry
- Chemical production

MAIN CHARACTERISTICS

- Large graphic display
- Colour backlighting
- On-line help
- Simultaneous measurement of conductivity, temperature and flow
- Simple, user-friendly and error-proof calibration software
- Mechanical relay and solid state relay for external alarms and for the control of external devices
- Multilingual menu
- USB port for software upgrade

TECHNICAL DATA

| | |
|----------------------------|--|
| General information | Compatible sensors: Conductivity/temperature sensors and Hall-effect flow sensors with frequency output or FLS F6.60 electromagnetic flow sensors |
| | Materials: – Case: ABS – Display: PC – Panel and wall gasket: silicone rubber – 5-button keyboard: silicone rubber |
| | Display: – LCD full graphic – Backlight version: 3 - colours – Backlighting activation: user adjustable with 5 levels of timing – Update rate: 1 second – Protection class: IP65 front |
| | Conductivity input range: 0.055÷200000 µS/cm (according to the applied cell constant) |
| | Conductivity measurement accuracy: ±2.0% of reading value |
| | Temperature input range: -50÷150 °C (-58÷302 °F) (with Pt100-Pt1000) |
| | Temperature measurement resolution: 0.1°C/°F (Pt1000); 0.5°C/°F (Pt100) |
| | Flow input range (frequency): 0÷1500Hz |
| | Flow input accuracy (frequency): 0.5% |

| | |
|----------------------------------|--|
| Electrical data | Supply voltage: from 12 to 24 VDC ±10% regulated |
| | Max electrical consumption: < 300 mA |
| | FLS Hall effect flow sensor power supply: – 5 VDC at < 20 mA – Optically isolated from current loop – Short circuit protected |
| | 2 current output: – 4–20 mA, isolated, fully adjustable and reversible – Max loop impedance: 800 Ω @ 24 VDC – 250 Ω @ 12 VDC |
| | 2 solid state relay outputs: – User selectable as MIN alarm, MAX alarm, pulse output, window alarm, off – (conductivity) User selectable as ON-OFF, proportional frequency output, timed pulses, off – Optically isolated, 50 mA max sink, 24 VDC max pull-up voltage – Max pulse/min: 300 – Hysteresis: user selectable |
| | 2 relay output: – User selectable as MIN alarm, MAX alarm, pulse output, window alarm, off [PS:EPT:(conductivity) User selectable as ON-OFF, proportional frequency output, timed pulses, off – Mechanical SPDT contact – Expected mechanical life (min. operations): 10 ⁷ – Expected electrical life (min. operations): 10 ⁵ switching N.A./N.C. capacity 5 A/240 VAC – Max pulse/min: 60 – Hysteresis: user selectable |
| Environmental data | Operating temperature: from –10 °C to 70 °C (from 14°F to 158 °F) |
| | Storage temperature: from –30°C to +80°C (from –22°F to +176°F) |
| | Relative humidity: from 0 to 95% not condensing |
| Standards & Approvals | Manufactured under ISO 9001 Manufactured under ISO 14001 CE RoHS Compliance EAC |

ELECTRICAL CONNECTIONS

Rear view of electrical connections

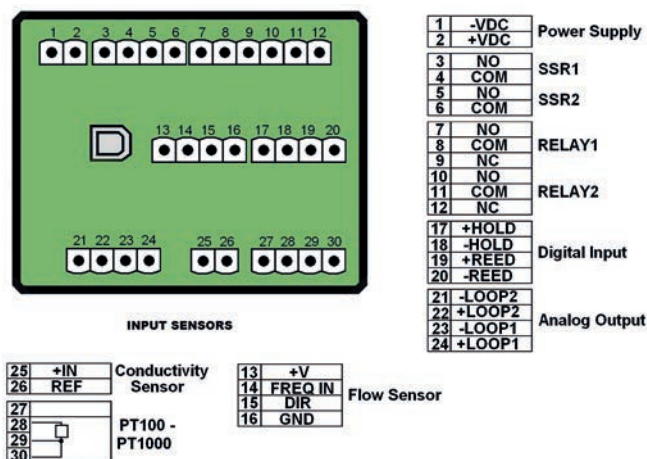

PRODUCT CODES



M9.07.P1 - M9.07.WX

Dual parameter conductivity and Flow Monitor and Transmitter

| Code | Mounting | Power supply | wires power Technology | Sensor Input | Output | Weight (gr.) |
|----------|----------|---------------|------------------------|---|--|--------------|
| M9.07.P1 | Panel | 12 - 24 VDC | 3/4 wires | Conductivity temperature Flow (Frequency) | 2*(4-20mA) 2*(S.S.R.) 2* (mech. relay) | 550 |
| M9.07.W1 | Wall | 12 - 24 VDC | 3/4 wires | Conductivity temperature Flow (Frequency) | 2*(4-20mA) 2*(S.S.R.) 2* (mech. relay) | 650 |
| M9.07.W2 | Wall | 110 - 230 VAC | 3/4 wires | Conductivity temperature Flow (Frequency) | 2*(4-20mA) 2*(S.S.R.) 2* (mech. relay) | 750 |

S.S.R: solid state relay / mech relay.: mechanical relay