

# FLS F6.60 - F6.63

Electromagnetic Flow Sensor



# FLS F6.60 – F6.63

The FLS F6.60 and F6.63 electromagnetic flow meters, thanks to the absence of mechanical moving parts, can be used for the measurement of dirty liquids as long as they are conductive and homogeneous.

The F6.60 product range offers three different options: frequency output for connection to flow indicators; 4–20 mA output for long-distance transmission and connection to PLC; new freely adjustable volumetric pulse output. The range of electromagnetic insertion meters is equipped with a USB interface and dedicated software (downloadable free of charge from the Aliaxis website) that allows you to easily set, via PC, all the installation parameters and relevant calibration. The specific design guarantees accurate flow measurements over a wide range of pipe sizes, from DN15 (0.5") to DN600 (24").

## ELECTROMAGNETIC FLOW SENSOR

### APPLICATIONS

- Water and wastewater treatment
- Raw water treatment
- Industrial water distribution
- Textile industry
- Swimming pools, spas and aquariums
- HVAC systems (heating, ventilation and air conditioning)
- Processing and manufacturing industry

### MAIN CHARACTERISTICS

- Absence of moving parts, wear and maintenance
- High mechanical strength
- Precise measurement of dirty liquids
- Pipe size range: from DN15 (0.5") to DN600 (24")
- Adjustable flow range
- Low pressure drop
- User-settable operating parameters
- 4–20 mA output, frequency or volumetric pulses
- Bi-directional selectable flow measurement (for F6.60)

### TECHNICAL DATA

#### General information

**Pipe size range;** from DN15 to DN600 (0.5–24") For more details, refer to the Installation Adapters section

**Max flow rate range:**

- F6.60: from 0,05 to 8 m/s
- F6.63: from 0,15 to 8 m/s

**Full scale:** 8 m/s (26,24 ft/s)

**Linearity:** ±1% of reading + 1.0 cm/s

**Repeatability:** ±0,5% of reading

**Protection class:** IP65

**Materials:**

- Case: ABS

**Materials in contact with liquids:**

- Sensor body: AISI 316L stainless steel and PVDF
- O-ring: EPDM o FKM
- Electrodes: AISI 316L stainless steel

<b>Electrical data</b>	<b>Power supply:</b> 12 to 24 VDC ±10% regulated (reverse polarity and short circuit protection)
	<b>Max electrical consumption:</b> 150 mA] – Ground connection: < 10 Ω
	<b>1 Current output:</b> – 4-20 mA, isolated – Max loop impedance: 800 Ω @ 24 VDC - 250 Ω @ 12 VDC – Positive or negative flow indication
	<b>1 solid state relay outputs:</b> – User selectable as MIN alarm, MAX alarm, volumetric, pulse output, window alarm, off – Optically isolated, 50 mA max sink, 24 VDC max pull-up voltage – Max pulse/min: 300 – Hysteresis: user selectable
	<b>Open collector output frequency:</b> – Type: NPN Open collector – Frequency: 0-800 Hz – Max pull-up voltage: 24 VDC – Max current: 50mA, current limited – Compatible with M9.02, M9.03, M9.50, M9.07, M9.08 and M9.10
<b>Open collector output direction (not available on model F6.63):</b> – Type: NPN Open collector – Max pull-up voltage: 24 VDC – Max current: 50mA, current limited – Flow direction: – 0 VDC in the direction of the arrow – + VDC in the opposite direction of the arrow	
<b>Environmental data</b>	<b>Storage temperature:</b> from -30°C to +80°C (from -22°F to +176°F)
	<b>Ambient temperature:</b> -20 to +70°C (from -4 to 158°F)
	<b>Relative humidity:</b> from 0 to 95% not condensing
	<b>Fluid conditions:</b> – homogeneous liquids, doughs or sludge, even with solid contents – Min electrical conductivity: 20 µS/cm – Temperature: Model with PVDF bottom: from -10°C to +60°C (from 14°F to 140°F)
	<b>Max operating pressure:</b> – 16 bar a 25 °C (232 psi a 77 °F) – 8,6 bar a 60 °C (124 psi a 140 °F)
<b>Standards &amp; Approvals</b>	Manufactured under ISO 9001 Manufactured under ISO 14001 CE RoHS Compliance EAC

## ELECTRICAL CONNECTIONS

Rear view of electrical connections

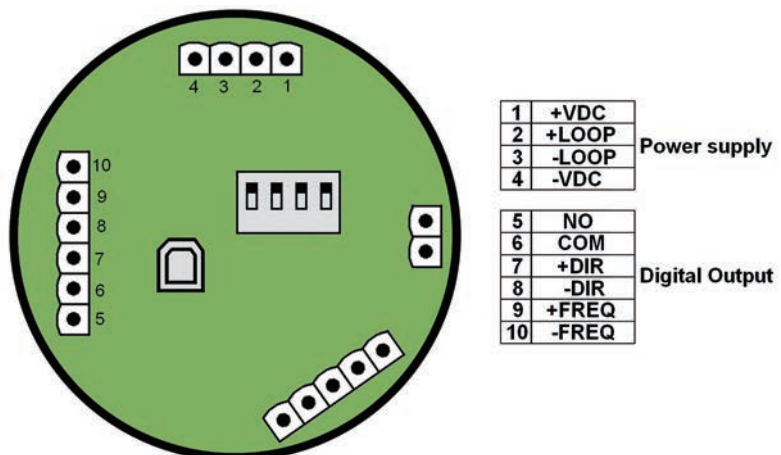

# PRODUCT CODES



## F6.60.XX

Electromagnetic Flow Sensor

Code	Version	Power supply	Length	Main Wetted Materials	Enclosure	Flow Rate Range	Weight (gr.)
F6.60.09	Blind	12 - 24 VDC	L0	316L SS EPDM	IP65	From 0,05 to 8 m/s bi-directional	950
F6.60.10	Blind	12 - 24 VDC	L0	316L SS FKM	IP65	From 0,05 to 8 m/s bi-directional	950
F6.60.11	Blind	12 - 24 VDC	L1	316L SS EPDM	IP65	From 0,05 to 8 m/s bi-directional	1000
F6.60.12	Blind	12 - 24 VDC	L1	316L SS FKM	IP65	From 0,05 to 8 m/s bi-directional	1000

## F6.63.XX

Electromagnetic Flow Sensor

Code	Version	Power supply	Length	Main Wetted Materials	Enclosure	Flow Rate Range	Weight (gr.)
F6.63.09	Blind	12 - 24 VDC	L0	316L SS EPDM	IP65	From 0,15 to 8 m/s*	950
F6.63.10	Blind	12 - 24 VDC	L0	316L SS FKM	IP65	From 0,15 to 8 m/s*	950
F6.63.11	Blind	12 - 24 VDC	L1	316L SS EPDM	IP65	From 0,15 to 8 m/s*	1000
F6.63.12	Blind	12 - 24 VDC	L1	316L SS FKM	IP65	From 0,15 to 8 m/s*	1000

# TECHNICAL DRAWINGS

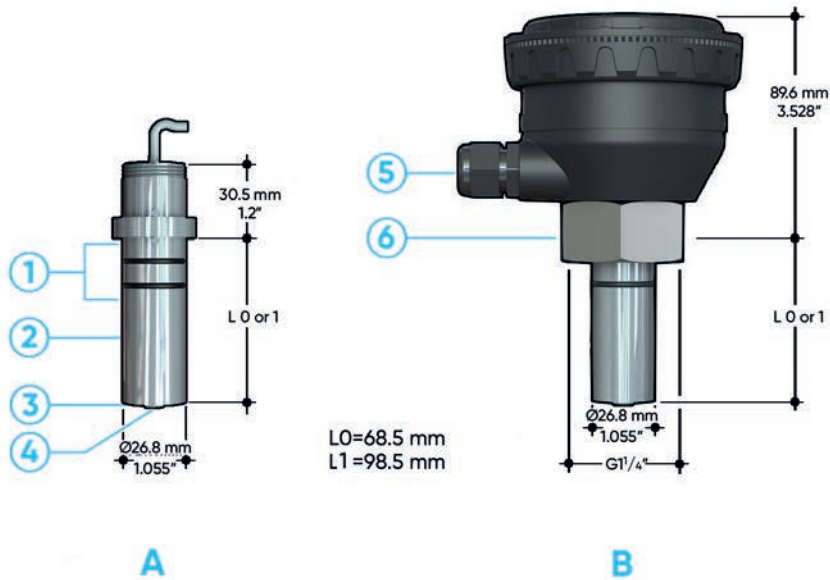

- A** Sensor body
- B** F6.60 - F6.63 Electromagnetic Flow Sensor
- 1** O-Ring (EPDM or FKM)

- 2** Sensor body (AISI 316L stainless steel)
- 3** Isolation Plate (PVDF)
- 4** Electrodes (AISI 316L stainless steel)

- 5** Cable Gland
- 6** AISI 316L stainless steel cap for installation on adapters
- 7** Electronic box