

FLS F3.10

Mini paddlewheel flow sensor



FLS F3.10

The simple and reliable paddlewheel technology was adopted in this type of FLS F3.10 mini flow sensor model, designed for use with any type of solid-free liquids. The sensor is capable of measuring flows from 0.25 m/s (0.8 ft/s) producing a highly repeatable output frequency signal. Extremely solid construction and consolidated technology ensure exceptional returns, with zero or very little maintenance. Due to its highly compact size and particular design, it is suitable for installation on standard FLS T adapters from DN15 to DN40 (0.5-1.5 inches).

MINI PADDLEWHEEL FLOW SENSOR

APPLICATIONS

- Water treatment
- Filtration systems
- Production of pure water
- Water monitoring
- Fertilization

MAIN CHARACTERISTICS

- IP68 protection class
- ABS body with EPDM or FKM gasket
- 4-blade ABS paddlewheel (without bearings)
- Mono-directional design
- Installation on FLS standard T adapters
- Model with PVDF body on request

TECHNICAL DATA

General information	Pipe size range: from DN15 to DN40 (from 0.5 to 1 1/2 inches). For more details, refer to the Installation Adapters section
	Flow range: from 0.25 to 4 m/s (0.8-12.5 ft/s)
	Linearity: ±1% of full scale
	Repeatability: ±0.5% of full scale
	Minimum Reynolds number required: 4500
	Protection class: IP68
	Operating pressure: – max 10 bar (145 psi) at 20°C (68°F) – max 2 bar (30 psi) at 70°C (158°F)
Electrical data	Operating temperature: from -20 to +70°C (from -4 to 158°F)
	Materials in contact with liquids: – Sensor body: ABS (PVDF on request) – O-ring: EPDM or FKM – Rotor: ABS (PVDF on request) – Shaft: AISI 316 Stainless Steel – Magnets: SmCo ₂
	Supply current: < 30 mA at 24 VDC
	Output signal: – Square wave: – Output frequency: 15 Hz for nominal m/s (4.6 Hz for nominal ft/s) – Output type: NPN Open collector transistor – Output current: max 10 mA
	Cable length: 2m standard (6,5 ft), max 300 m (990 ft)
	Standards & Approvals
	Manufactured under ISO 9001 Manufactured under ISO 14001 CE RoHS Compliance EAC

F3.10 IP68 SENSOR ELECTRICAL CONNECTIONS

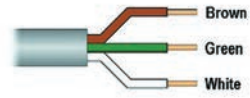

M9.02

SENSOR	
5	GND
6	IN
7	V+

ELECTRICAL CONNECTIONS TO OTHER FLS MONITORS

	M9.00	M9.50	M9.03 input 1	M9.03 input 2	M9.07	M9.08	M9.10
GND	7	30	30	16	16	16	37
FREQ	8	28	28	14	14	14	36
V+	9	27	27	13	13	13	35

PRODUCT CODES



F3.10.H.XX

Mini Paddlewheel Flow Sensor

Code	Version	Power supply	Length	Main Wetted Materials	Enclosure	Flow Rate Range	Weight (gr.)
F3.10.H.01	Hall	5- 24 VDC	41 mm	ABS EPDM	IP68	From 0,25 to 4 m/s*	100
F3.10.H.02	Hall	5- 24 VDC	41 mm	ABS FKM	IP68	From 0,25 to 4 m/s*	100

*From 0,25 to 4 m/s= (0,8-12,5 feet/s)

TECHNICAL DRAWINGS

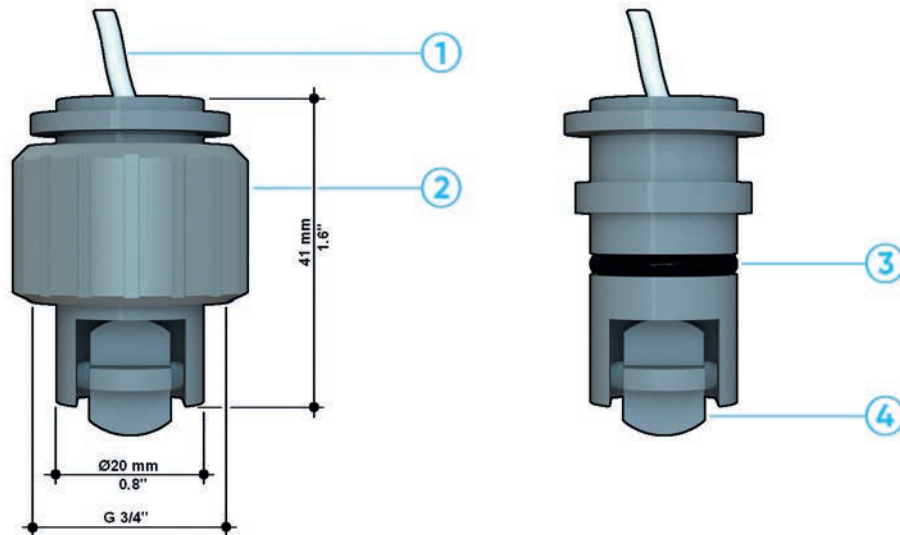

F3.10

- | | | | |
|----------|---|----------|---|
| 1 | Electrical cable: 8 m. (26.4 ft) standard | 3 | O-Ring seals available in EPDM or FKM |
| 2 | U-PVC cap for installation into fittings | 4 | ABS rotor with 4 blades and stainless steel shaft |